

Hunzeweg 57, 9893 PB
Garnwerd, Groningen (NL)
+31 5941 1525 |cgl@risc1.rug.nl

What is T_EX and METAFont all about?

Kees van der Laan

August 12, 1994

Contents

Introduction

- T_EX etc. tools
 - Importance
 - T_EX's flavours, drivers, and fonts
 - Descriptive mark-up
 - T_EX its author, users, and publishers
 - T_EX and other EP tools
 - Trends
 - Examples: generic format, and
in the small math, tables, and graphics
 - Front & back matter
 - Guidelines for choosing
- Acknowledgements, Conclusions, References.

Introduction

This work about computer-assisted typesetting by (L^A)T_EX and METAFONT in context, is aimed at a broad audience. Novice users à la BLU¹ who like to become informed what it is all about, advanced L^AT_EX users who hardly have heard of `manmac`, and mathematicians and publishers who will find the offerings of the American Mathematical Society interesting.

There have been published many notes, articles and books about T_EX. Advanced ones exploring T_EX's limits, and also contributions at the survey and introductory level. The latter deal with the macroscopic mark-up features as well as the microscopics of automatic kerning, for example with A and V in AV, the automatic handling of ligatures, the automatic justification and hyphenation supported by hyphenation tables, and the formatting of math, tables and

¹BLU is Knuth's nickname for the innocent user, the so-called Ben Lee User of the T_EXbook fame, with BLUe its cousin, adopted by me. Nowadays we would say Beginning L^AT_EX User.

graphics. They also boast of the quality which can be obtained when formatting the typographic teasers: math, tables and graphics.

In the \TeX niques series we have the tutorials: A gentle introduction to \TeX , by Michael Doob, and First grade \TeX , by Arthur Samuel. For \LaTeX there is: An introduction to \LaTeX , by Michael Urban, and—for the Dutch speaking community—Publiceren met \LaTeX , by de Bruin. Also noteworthy is Hoenig's \TeX for new users, and the introduction chapter in Salomon's courseware Insights and Hindsight. For METAFONT see Henderson's An introduction to METAFONT , Tobin's METAFONT for beginners, and Knuth's introductory article on the issue in TUGboat. A survey with respect to EP tools (Electronic Publishing) is Document Formatting Systems: Survey, Concepts and Issues, by Furuta and co-authors.

For trying it out and working with it, the user groups distribute PD versions of (La) \TeX as well as integrated working environments for PCs, with all kinds of bells-and-whistles added. Ubiquitous is Mattes' PD $\text{em}\TeX$, and the working environments $\text{As}\TeX$ (apart from Framework it is in the Public Domain), next to the Dutch $4\TeX$ (which is shareware).

This paper relates \TeX and METAFONT to EP, SGML and the like, as a helicopter view, and accounts for the many activities of its users. At the end an annotated bibliography has been supplied.

Conventions and notations. I adhered to the historical development of \TeX et cetera, and did not order the tools with respect to perceived importance. The latter is a matter of taste and definitely time-dependent.

The Contents list is not a one-to-one mapping of the section titles. It is used to stress the main items and their treatment within a logical hierarchy. I clustered some section titles and subsection titles, whenever convenient, to enhance readability. The aim was to convey the contents and not so much the form, to paraphrase Marvin Minsky.

Because it is a 'helicopter' view I need to refer to other work. This has been done a little loose via the name of the (first) author and the title, or keywords form the title. The reader can easily spot from the supplied list of references which work is hinted at. Just start by the author name and look for the matching title. I also did not bother about traditions which require that book titles are set in italics or so. In my opinion to find out whether it is a book, a report or a journal article follows easily from the ISBN number if provided, respectively the journal name. Hereby I assume that readers are familiar with some journal names, for example TUGboat, the journal of the \TeX Users Group.

For common words in the \TeX arcana—like \TeX , \LaTeX , American Mathematical Society, et cetera—I adopted the TUGboat typesetting conventions by using their macros for formatting these names. File names are set in the `\tt` font.

1 T_EX etc. tools

First of all T_EX etc. has been around for some fifteen years, and many of its users have contributed to the components and to the porting to many platforms, with the result that it is not easy to really survey the whole complex.

Going back to the roots we can say that T_EX is a program for formatting documents, born as a twin with its sister METAFONT, for creating fonts. T_EX and METAFONT have been designed to facilitate the high-quality computer-assisted production of books. A more modern way of talking is that T_EX is a mark-up language with METAFONT the accompanying tool for designing the needed graphics, starting with the fonts.

A nice survey of the most important components and files when working with T_EX is supplied by the accompanying diagram,² which illustrates the two main fields: font design and typesetting, with the relations between the components and files, all in one, and abstracting from details.

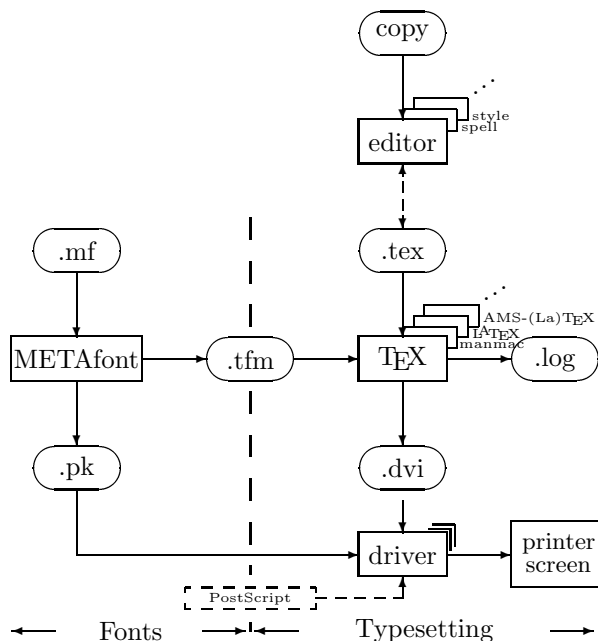

That is

- the flow from copy to printed results
- where the editor and its associated tools come in
- the location of T_EX—its flavours, and add-ons—at the heart

²Inspired by Salomon's diagram as supplied in his courseware: Insights and Hindsight.

- what is used from METAFONT and where
- the printer independence via various drivers
- at what level PostScript can be included.

The important files are indicated by their extensions and are depicted within ovals. What holds for creating the `.tex` file holds also for the `.mf` file.³

1.1 Working environments.

The needed tools are nowadays embedded in computer-assisted (scientific) working environments. At first sight this seems trivial, but it is really handy that the tools are integrated, also with non-formatting applications per se, such as email, database applications and the old running of C or FORTRAN programs. A model of thinking is that, for example, a thesis is prepared and all the simulations and calculations are done as a side-step of the main work: publishing! That is document preparation, formatting, typesetting, and dissemination. The graphics-oriented PCs like Macintosh and Atari paved the way. Nowadays the 486-based PCs with their (graphics) window facilities allow this way of working too.

1.2 Installation.

The products are usually accompanied by their installation documentation. Famous, and top class, are the AMS installation Guides. With the PD PC versions the idea is to supply turn-key scripts so that the installation goes automatically. From those distributed by the TUG/LUGs the only nice one I have seen is the GUTenberg PD PC set and installation guide, prepared by Lavaud. Installation of the working environments is more complicated, because of the many components.

1.3 Lifetime.

The kernel T_EX and METAFONT programs have been designed with flexibility and portability in mind. Knuth envisioned that the two could be used a hundred years from now, just as we do today, with the same input and results!⁴ In order to make this possible Knuth

- invented the WEB literate programming way of working
- documented the programs (open system) well

³Not mentioned are virT_EX and iniT_EX. Erik-Jan Vens communicated the following functionalities on the TeX-nl network: ‘iniT_EX allows preparing and fast loading of `.fmt` files. VirT_EX is a program that can accept fast your macros and then do the typesetting job proper.’

⁴Or better.

- worked hard on making the systems error free
- delivered the twins into the public domain, and
- froze the kernels.

Because of these goodies the user community could port the systems to any conceivable platform, and add layers on top to adjust for users' wishes and demands. All-in-all one can say that the twins are portable in place and time, are powerful, useful, and will serve a lifetime.

The working environments suffer from a much shorter lifetime. Read: need continuous maintenance and that is something, especially in a volunteer-based world. It is always a matter of the right balance: how fast do I need to do the day-to-day work and how often do I wish to upgrade the working environment.

2 Importance

From the computer science point of view TEX and $\text{M}\text{E}\text{T}\text{A}\text{F}\text{O}\text{N}\text{T}$ are big research achievements in how software engineering should be done, if not for the literate programming way of software design and creation. Top-class algorithms for line-breaking, hyphenation and page make-up have been incorporated. It is designed to be device-independent. That Knuth succeeded so well in his basic research can be witnessed by the many publications which have been built upon his Computer and Typesetting works, and the many honorary degrees he has received.

From the users' point of view TEX etc. is relevant because of the quality which can be obtained when used as a formatter. TEX is an open and freely available system. It has been frozen, and delivered into the public domain to serve for a lifetime. That Knuth succeeded here so well can be distilled from the many organized users of $(\text{L}\text{A})\text{T}\text{E}\text{X}$ world-wide, and perhaps the tenfold more who just use the systems.

Its weakness is that TEX proper does *not* have easy user guides. This weakness has been compensated for by efforts like $\text{L}\text{A}\text{T}\text{E}\text{X}$, $\mathcal{A}\mathcal{M}\mathcal{S}\text{-T}\text{E}\text{X}/\text{L}\text{A}\text{T}\text{E}\text{X}$, and the styles from publishing houses and their user and installation guides. Perhaps an unexpected side-effect of TEX is that it is so heavily used with alphabets different from Latin, and even with scripts which run from right to left (Hebrew) or scripts which run vertically (Japanese), not to mention specific hyphenation patterns. That TEX allows for these usages might give an idea of its power.

From the publishers' point of view TEX has the potential of being used for producing complex scientific documents cost-effectively. This is the current practice of the American Mathematical Society, and the American Physical Society, APS for short. They supply authors with

- user and installation guides

- fonts
- style files
- templates, and
- support, in general.

The advantages can be summarized as

- high-quality craftsman tool
- lingua franca for exchange of typographically complex documents
- stability (T_EX kernel has been frozen)
- open system
- available for nearly all platforms
- in the public domain
- portable, flexible, extensible, . . .
- 7.5–10k organized users world-wide
- cost-effective production tool.

Disadvantages are there any? Of course there are. But it is questionable whether one should talk about disadvantages. Perhaps one should talk more in terms of incompleteness.

What is felt like an omission can be added, because it is an extensible system.

I for one miss that `manmac.sty`—Knuth’s macros for formatting his books—doesn’t take a user guide, nor does plain T_EX. Of course there is the T_EXbook—the bible for the T_EXies—but that does *not* hide the details—it is all there, for the beginner as well as for the advanced macro writer—which is confusing and simply too much for a novice. In summary

- (L^A)T_EX is not WYSIWYG-like⁵
- unusual macro language⁶

⁵Usually commercial.

⁶It is always a matter of education, and after that the *unusual* issues metamorphose into paradigms.

- complex: \approx 1k commands, parameters, ...⁷

So its incompleteness is a challenge to all of us, to fill it up.

It is true, however, that professionals have found some niches which deserve further research and development. Surveys on these items are provided in the E-TeX paper by Mittelbach, and the New Typesetting System efforts initiated by the German-speaking users group DANTE. Also noteworthy is the effort to improve L^ATeX via the so-called L^ATeX3 (better known as l^xiii) project.

One can also argue that delving into these details is sub-optimization, concentrating too much on the mapping onto paper. Bigger issues are related to the multi-media aspects, let us say to represent information in a flexible way such that it can be processed by various technologies, into forms suited for various users, their circumstances and their tastes, limited only by their senses. I like to call this *real* applied information technology: information to be accessed by the masses.

3 TeX's flavours

TeX has gotten its children already, like `manmac`, L^ATeX, and $\mathcal{A}\mathcal{M}\mathcal{S}$ -TeX/L^ATeX, to name but a few. As usual with children they live their own lives. For TeX this means that they have the confusing side-effect of not being completely compatible. In spite of this incompatibility reality has it that authors and publishers make their choice—TeX-based, or L^ATeX-oriented—and therefore the incompatibilities don't hinder most of us.

`manmac.sty` is a set of macros written and used by Knuth to format his magnum opus: The Art of Computer Programming, his Computers and Typesetting series, and so on. For an account see my Manmac BLUes.

L^ATeX stresses the higher-level approach of descriptive mark-up and hides the formatting details as much as possible from an author. Because of the rigorous way this has been implemented, it is hard to customize the prefab styles.

Leslie Lamport's manual, L^ATeX, A Document Preparation System, exhibits the functionalities

- prefab styles: article, book, letter, report, slides
- automatic (symbolic) numbering and cross-referencing
- multi-column formatting, with its embedded 1-column occasionally for tables and figures

⁷Abstraction, subsetting and user guides—like those of $\mathcal{A}\mathcal{M}\mathcal{S}$ -TeX—are needed. Tools which concentrate on the publishing goal and not so much on understanding and learning the formatting language per se.

- automatic generation of ToC, LoT, LoF
- picture environment
- bibliography environment.

$\mathcal{A}\mathcal{M}\mathcal{S}\text{-}\mathbb{T}\mathbb{E}\mathbb{X}/\mathbb{L}\mathbb{A}\mathbb{T}\mathbb{E}\mathbb{X}$ are the tools of the pace-setting American Mathematical Society. This publisher adopted and supported the $\mathbb{T}\mathbb{E}\mathbb{X}$ development from the beginning. (See below under $\mathbb{T}\mathbb{E}\mathbb{X}$ and its publishers.)

$\mathbb{L}\mathbb{A}\mathcal{M}\mathcal{S}\text{-}\mathbb{T}\mathbb{E}\mathbb{X}$ reimplemented in a flexible way the descriptive $\mathbb{L}\mathbb{A}\mathbb{T}\mathbb{E}\mathbb{X}$ approach, next to a general automatic numbering and symbolic referencing scheme, advanced table macros, and sophisticated commutative diagram macros. See my review of Spivak's oeuvre for more details about the Joy of $\mathbb{T}\mathbb{E}\mathbb{X}$ and $\mathbb{L}\mathcal{A}\mathcal{M}\mathcal{S}\text{-}\mathbb{T}\mathbb{E}\mathbb{X}$ —The Synthesis.

In summary

- `manmac.sty`, Knuth's format
- $\mathbb{L}\mathbb{A}\mathbb{T}\mathbb{E}\mathbb{X}$, descriptive mark-up, and user's guide
- $\mathcal{A}\mathcal{M}\mathcal{S}\text{-}\mathbb{T}\mathbb{E}\mathbb{X}/\mathbb{L}\mathbb{A}\mathbb{T}\mathbb{E}\mathbb{X}$ styles and fonts, with support
- $\mathbb{L}\mathcal{A}\mathcal{M}\mathcal{S}\text{-}\mathbb{T}\mathbb{E}\mathbb{X}$
- TUGboat styles
- PD software and working environments

4 $\mathbb{T}\mathbb{E}\mathbb{X}$'s drivers

Normally the drivers come with your $\mathbb{T}\mathbb{E}\mathbb{X}$ when you buy it. With the PD versions, users have to be aware of the PD available drivers, for the various PCs and printers, unless your user group provides you with an integrated working environment which contains all. For a survey of the available 'Output device drivers' see Hosek's paper in TUG's resource directory. He details drivers for

- laser xerographic and electron-erosion printers
- impact printers and miscellaneous output devices
- phototypesetters
- screen previewers

and ends up with supplier information. Joachim Schrod reported in TUGboat 13, 1, (early 1992) from the TUG DVI driver standards committee.

Well-known is the PD Beebe driver family. emTeX comes with some drivers for dot matrix printers and the HP LaserJets.

At the TUG '92 meeting the attendees were surprised by Raman's paper 'An audio view of (La)TeX documents.' It has all to do with representing the contents of a publication for the blind.

With respect to PostScript the `dvitops` driver is important. Formerly, I also used `dvitodvi` in order to print out selected pages. Now I use `manmac`'s facility to do that which is essential simpler for that purpose because it ships out only the required pages.

5 TeX and fonts

From the beginning Knuth provided TeX with the computer modern family of fonts. These fonts can be generated, and varied via METAFONT, by adjusting some parameters. Since the introduction of the virtual font concept, in revision '89 better known as TeX version 3, many industrial fonts can be used as well. Via this mechanism, font elements can be combined at the driver level. The need for handling in a flexible way the positioning of diacritical marks was the incentive for adding the virtual font concept, to make it feasible to handle languages with their own special placements of diacritical marks without the need to regenerate complete new fonts. The other way is to generate complete font tables for every language, which is a perfectly acceptable way of doing it, but will entail many font tables and of larger size.⁸

However, since TeX is used for more and more applications the need for more fonts—different shapes, sizes and so on—has emerged. Using standard bitmap technology much computer memory is needed. Reality has it that scaling fonts linearly does not yield pleasing results. To compensate for this the intelligent scalable fonts technology emerged—near-linear and intelligent, that is with some enhancements—as opposed to the classical memory-consuming bitmap fonts, extended by the linear scaling as such.

Also the mark-up for fonts has gotten a new dimension: the linear space of available fonts is seen as a 4-dimensional space governed by the coordinates family, serie, shape, and size. The approach goes with the buzzword NFSS, New Font Selection Scheme (See Goossens, Mittlebach and Samarin).

⁸Reality has it that the TeX community standardized on the 256-character DC font tables, to allow for some special characteres, like the use of the ij in Dutch. See Haralambous' paper in TTN 1, 4. An entirely different approach is needed for the Japanese ideograms, that is symbols representing things or ideas. At present there are some 6,353 kanji characters available on various types of computers known as JIS level 1 or 2 (Japanese Industrial Standard is akin to ASCII.)

Which fonts can be used with T_EX? The following classes of *text* fonts can be used with T_EX

- CM, the native Computer Modern
- 14,000 fonts in industry standard Adobe type 1
- several hundreds in formats such as TrueType.

(Very) few fonts can be used with math, because of the specialities of the font characteristics T_EX assumes. However, the following fonts can be used with math

- CM math, the native Computer Modern
- lucida math
- lucida newmath
- mathtimes.

For more details see Horn's Scalable outline fonts paper, and for Japanese Fujiura in TTN 1, 2.

6 Descriptive mark-up

Since the start of computer-assisted typography attention has been paid to abstraction from details, to the principle of the *separation of concerns*.

Leading in this area is the SGML approach.⁹ It is argued that

authors should concentrate on the contents—and inherently on the structure—of their documents, leaving the details for formatting to the publisher.

Example: (Call for papers, Furuta)

```
\input cfp.tex%contains format and macros
%next copy proper
The aim of this paper...

Paper are solicited on ...
\lstitm Picture editing
\lstitm Text processing
\lstitm Algorithms and software...

Detailed abstracts should not ...

Duration of presentation...
\bye
```

⁹The relation between SGML and T_EX will be discussed later.

The above example is a mixture of natural input, where blank lines have an intuitive but context-dependent meaning, and of handling trivia automatically behind the scenes. An example of a default is the heading.

For this format the heading is always the same, so there is no need for a user to provide it each time the format is used. It comes along with the format. So do the fonts used and the shortcuts like `\def\lstitm{\item{--} }`.

My approach looks simpler than Furuta's—in that paper all the low-level formatting details were there—because I applied the principle of the separation of concerns and abstracted from the low-level formatting details. The point I'd like to make is that it is possible to hide formatting details, to account for these separately and at a lower level. I like to call this approach generic, because the mark-up is customized at a lower level to the suited tool.

7 T_EX and its author

Don Knuth started the design of T_EX in 1978. The first major revision dates back to 1982. The final version is dated 1989, and called T_EX version π .¹⁰ It is all a side-step(!) of his magnum opus: *The Art of Computer Programming*, of which three volumes have appeared of the envisioned seven. Because of the rapid development in computer science volume four consists of three books already.

In designing and developing T_EX, Knuth adhered to several software engineering paradigms like: portability, flexibility, robustness, and not to forget correctness and documentation.¹¹ In order to do this gracefully he coined the words *literate programming*, and provided en-passant tools for practical use! In fact T_EX can be seen as a real-life and significant example of literate programming.

In designing T_EX he adopted and developed the following

- boxes, glue and penalties as building blocks
- paragraph-wise searching for line-breaks
- page mapping via the OTR,¹² optimizing for least penalties
- device-independent output, to be printed, typeset, or viewed, by independent driver programs
- virtual fonts.

T_EX was developed as a side-step. METAFONT can be seen as an off-off-spring.

¹⁰Essentially version 3, but because reality has it that even Knuth 'makes errors' he allows for adjusted versions denoted by the decimals of π : 3.1, 3.14, 3.141, et cetera.

¹¹The software crises of the seventies suffered much from inadequate documentation.

¹²A buzzword to denote the output routine which performs this task.

8 \TeX and its users

It is unknown how many people use $(\text{\La})\text{\TeX}$, and for what purposes. We know, however, that it is used all over the world, to typeset

- scientific documents, exchange and publish such documents¹³
- documents which require special fonts and layout conventions, like Japanese, Arabic, Hebrew and so on
- transparencies and slides
- material associated with a hobby (bridge, chess, crosswords, go, music, and add yours).

A great virtue of the users' action is

- the porting to various platforms
- to provide macros, fonts and formats
- to maintain \LaTeX
- to ponder about and develop New Typsetting Systems
- to develop and maintain integrated working environments.

The user groups. We also know that many users have organized themselves into user groups, to start with the original \TeX Users Group (TUG), and more recently into so-called LUGs—language-oriented local user groups. The Dutchies are organized since 1988 as the NTG, *Nederlandstalige \TeX Gebruikersgroep*, that is Dutch language-oriented \TeX Users' Group. We enjoy some 225 members of whom are 30 institutions.

World-wide some 7.5–10k users are organized.

The benefits of being organized, apart from those which come from cooperation and sharing in general, are

- meetings
- TUGboat, newsletter, casu quo bulletins, 'specials'
- resource directory (information about the $(\text{\La})\text{\TeX}$ working environments of members, their addresses and similar things)
- TUGboat styles

¹³For an impression of published books formatted via \TeX see Beebe's bibliography in the TUG resource directory.

- assistance
 - archives
 - BBS (Bulletin Board Services)
 - digests
 - FAQs (Frequently Asked QuestionS)
- courses
- PD sets (Public Domain)
- distributing point books (tutorials), software.

Moreover, the user groups stimulate and support research and development, such as the projects: T_EXHaX, B_IB_TE_X, and more recently L^AT_EX3, and NTS. From the social side we have the TUG bursary fund, to grant attendance for a TUG meeting for those TUG members who can't afford it, next to the Knuth Scholarship award. The latter is a competition which rewards the winner with attending a meeting for free.

Some addresses?

TUG: Balboa Building, Room 307, 735 State Street, Santa Barbara, Ca 93101, USA, tug@tug.org

NTG: Postbus 394, 1740 AJ Schagen, ntg@nic.surfnet.nl.

For other addresses consult the resource directory of TUG, or your friendly NTG around the corner.

8.1 Add-ons

have been provided by the user communities. They have also supplied mutual support, and have provided logistic facilities. The latter is not restricted to (L^A)T_EX proper. It is about the general use of the electronic networks

- exchange via e-mail
- electronic digests and list servers
- the file servers, which store all the macro and style files.

Really, very nice goodies! The proper add-ons concern

- porting the complex to every system, especially the affordable and widespread PCs
- macro and style files¹⁴

¹⁴A survey of what is provided is contained in the so-called Jones' index, and Beebe's TUGlib.

- extra fonts, casu quo font couplings via virtual font scripts
- WYSIWYG user interfaces (commercial)
- T_EX-based PD/shareware working environments
- language-specific issues (hyphenation patterns, reserved words, ...)
- drivers for new printers
- PostScript etc. inclusion at the dvi level.

And the end is not yet in sight.

9 T_EX and the publishers

The importance of the American Mathematical Society effort is that the AMS is leading in how (La)T_EX can be used cost-effectively as a high-quality tool in a production environment: publishers cooperating with authors.

As I understand it the American Physical Society is following the AMS approach.

At the TUG '91 meeting at Boston, it was estimated that commercial publishers handle some 5 to 10% of their (scientific) production via (La)T_EX.

And in the CIS—Commonwealth of Independent States, the former Russia—MIR has adopted the AMS approach as well. And then there is the Ukraine group to be founded officially this fall, and undoubtedly more to follow.

The American Mathematical Society do their complete production via T_EX: $\approx 100,000$ pages/year, and provide authors with

- (generic) styles
- macros, and fonts
- user guides
- support (keyboarding, mark-up, fine-tuning).

The approach can be depicted by the following scheme

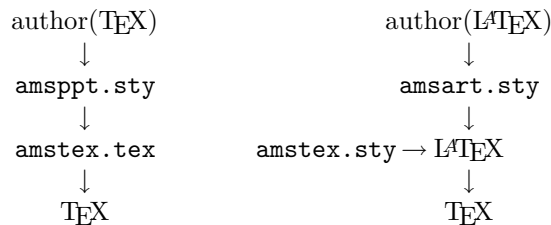

They also supply fonts: Euler, Fraktur, . . .

For more details consult the AMS sources or see my AMS BLUES paper on the issue.

The American Physical Society handle some 20% of their production via L^AT_EX. They cooperate with The Optical Society of America and the American Institute of Physics. Their style is called REV_TE_X.

MIR publishers Moscow—the driving force behind CyrTUG, the Cyrillic language-oriented T_EX users group¹⁵—translated Spivak’s The Joy of T_EX into Russian among others. I would not be surprised to hear that they do the production of their scientific documents with T_EX too, completely. They have the knowledge and T_EXnology. And T_EX- and METAFONT-based technology does not require much hard currency for investment.

JTUG? And what is going on in Japan? The JTUG has at least .5k members.¹⁶ They have translated among others the T_EXbook and the L^AT_EX manual into Japanese. Some years ago I received a Japanese newspaper set by J_TE_X!

10 T_EX and other EP tools

Furuta gives a good account of the history and early tools in relation with computer-assisted typesetting. However, since the appearance of that paper

- the laser printer technology has taken off
- many computer-based fonts have emerged
- thinking in structures has gotten more interest (SGML)
- the DTP (Desktop Publishing) credo has come into existence, and
- hardware prices have continued to spiral down.

Everybody can afford a PC, a laser(jet) printer, and some software (especially Word*whatever* or the PD (L^A)T_EX).

10.1 T_EX and intelligent editors.

Keyboarding compuscripts in (L^A)T_EX can be assisted by editors which are (L^A)T_EX intelligent, and next, to use templates as ‘fill-in’ forms. An example is Beebe’s L^AT_EX-intelligent emacs. This approach can prevent errors like the level 1 or so endings, or non-matching braces and the like. At this level we can also make use of spelling checkers and style assistants.

¹⁵See also ‘News about CyrTUG and Russian T_EX Users’ in TTN 2, 1.

¹⁶See also ‘Update of T_EX in Japan’ TTN 1, 2.

10.2 Word*whatever* and T_EX?

It is true that Word-you-name-it, has made the use of computers more popular. They replaced the typewriters, don't forget that. And of course that was a step forward. These are the tools the masses are using because of the sufficient and improved quality which can be obtained. This must be seen in context of course: most of the publications are just in-house reports, memos and the like.

For high-quality typesetting a T_EX-like tool, high-resolution fonts and ipso facto printer, or viewer, are needed.

Because wordprocessors are so widespread and heavily used, it can be anticipated that users start from there and need T_EX's formatting capabilities now and then. For that group there exist conversion software: the public domain DRILCON and the commercial K-Talk. Simpler, and better when it concerns complex structured copy, is to

output in ASCII from Word*whatever* and insert (L^A)T_EX mark-up.

And, of course, the wordprocessor can always be used as an editor for T_EX, with taking advantage of the integrated spelling checker.

10.3 Troff or T_EX?

Troff preceded T_EX. It comes with UNIX. Both have been in use for the last decade. To begin with Knuth built upon troff, scribe and similar tools. On the other hand the troff add-ons have learned from T_EX. So there has been mutual influence.

With respect to the functionality the tools are comparable. Both aim at computer-assisted typography. But there is also a world of difference. Basically the difference is that troff is a program which can be extended by independent preprocessors, and T_EX is an extensible language itself, with plain T_EX—the kernel program—device independent, that is the mapping on the media has to be done by independent drivers. That the latter was not in troff can be discerned from the subsequent nroff—with accompanying neqn—and finally, di-roff, device-independent roff. Furthermore, remember that T_EX is just one of the twins.

Rumour has it that interest in troff weakened because the early PCs did not come with UNIX, and that the kernel has remained undocumented (Its author Ossanna died in an accident.) The following table is supplied to indicate roughly the differences.

	(L ^A)T _E X	T/Di- <i>roff</i>
Costs	PD	licensed via UNIX
Availability	all platforms	under UNIX
Documentation	T _E Xbook (also on-line)	On-line manual
Fonts	METAfont's CM, virtual fonts	?
Design	open system	kernel undocumented
Printers	device independent	di- <i>roff</i> approach
Flexibility	complete	?
Extensibility	macros	preprocessors
Mark-up	formats and styles	ms macros
Coding	uniform in WEB	C
Future	kernel frozen, users augment	frozen
Acceptance	users, AMS, APS, . . .	users, ?

10.4 SGML and T_EX?

SGML stands for Standardized Generalized Mark-up Language. It is an effort to formalize mark-up, and is defined as a meta-language to define the mark-up language of each publication series into so-called Document Type Definitions, DTDs for short.

SGML is part of a huge standardization effort supported by the US military via the CALS initiative. Other components are: FOSI—Formatted Output Specification Instance¹⁷—and DSSSL.¹⁸ It is not so much a question of

T_EX *or* SGML, but more T_EX *and* SGML.

T_EX formats can learn a lot from the SGML approach and on the other hand SGML needs a formatter when it is used to print documents. This cooperative approach is known as

SGML the front-end, (L^A)T_EX the back-end.

A diagram about the SGML-T_EX relation is supplied in the accompanying picture.

10.5 SGML and Hypermedia?

The following has been contributed by Gerard van Nes (from SGML FAQs and Personal Computer Word, March 1992)

‘HyTime—Hypermedia/Time-based Structuring Language (ISO/IEC 10744). HyTime is a standard neutral markup language for representing hypertext, multimedia, hypermedia and time- and space-based documents in terms of their logical structure. Its purpose is to make hyperdocuments interoperable and maintainable over the long term. HyTime can be used to represent documents containing

¹⁷See Dobrowolski's paper.

¹⁸See Bryan's paper.

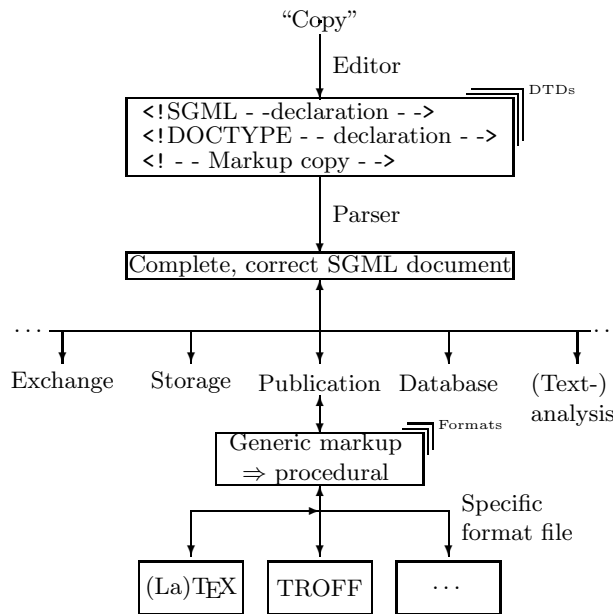

any combination of digital notations. HyTime is parsable as Standard Generalized Markup Language. HyTime was accepted as a full International Standard in spring 1992.

SGML's hypermedia capabilities have been beefed up in the SGML standard extension HyTime. Although it started out in life as a specific set of standards for representing music, it was soon realised that these could be generalised for multimedia. HyTime provides

- SGML itself
- Extended Hyperdocument management facilities, including support for various types of hyperlink
- A Coordinate Addressing Facility which positions and synchronises on-screen events. This allows authors to specify how hypermedia documents are to be rendered
- Better version-control of comments and activity-tracking policy support.

HyTime has been adapted as the basis for hyperlinking in the US Department of Defense's Interactive Electronic Technical Manual project. HyTime is an extension of SGML, providing a set of syntactic constructs: it doesn't specify a processing system.'

Sounds very promising!

10.6 \TeX within the context of EP.

When we think about Electronic Publishing we can't avoid being aware of the life-cycle of publications. This obeys the biological invariant: produce, consume and reuse.

Life-cycle: producing.

The production process has all to do with the dimensions

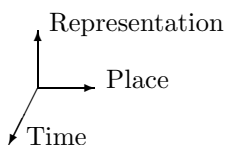

and with the characteristics

- representation of the contents, that is the typesetting proper aspects
- logistics, that is distribution and selling points—the place dimension
- reuse, that is the time aspect, when (parts of) document are reused.

The flow can be depicted via

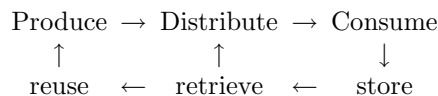

The big features are the unambiguous mark-up of copy via $(\text{\LaTeX})\text{\TeX}$ and the lifetime of the \TeX kernel. Therefore storing documents formatted by \TeX , leaves the reuse aspect open. Reality has it that documents formatted via \TeX are easily redistributed via the electronic networks, because it is all in ASCII, and \TeX is everywhere, so are its drivers.

My day-to-day reuse is transforming reports into articles and these into transparencies. In this work it is the other way round I'm recollecting elements I have set earlier. Similarly with the book I'm working on Publishing with \TeX . Actually my first work in the document preparation area, in the early eighties, was called 'Van rapport naar transparant.'

Life-cycle: consuming.

\TeX 's drivers have not paid attention to other representations as yet, although an exception is a driver for the blind. Difficulties in formatting languages different from English have been exercised in recent years. Undoubtedly research will be devoted to the aspects hinted at in the diagram given below with the dimensions

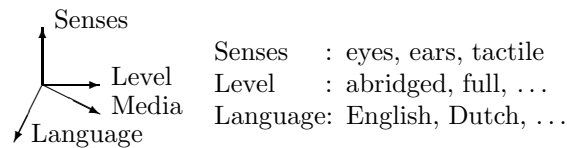

and with the characteristics

- choice of consumer language independent of the submitted language, that is automatic translation
- choice of representation, that is for example voice output from written submission.

Of course the above aspects will keep research busy for some time to come. This is the direction multi-media development will go.

11 Trends

Adobe has been the trendsetter of the last decade with respect to new EP technologies. Recently, I heard about their PDF—Portable Document Format—which is at the heart of their Acrobat. Very promising, if not for the tools which come along with this product.

I believe that the multi-media information technology will take off in the next century. Much is known under the buzzword hypertext. See the special issue of the Communications of the ACM for an introductory survey. As a \TeX ie it is fun to ponder about what niche there will be for \TeX . At the various TUG meetings people are concerned about the future of \TeX and share their doubts and optimisms. From that the following anthology

- \LaTeX is the future, forget about \TeX
- make $(\text{\La})\text{\TeX}$ available on low-cost machines
- embed \TeX etc. in working environments
- improve \TeX , in short keep it alive
- provide WYSIWYG user interfaces
- increase the number of (organized) $(\text{\La})\text{\TeX}$ users
- get $(\text{\La})\text{\TeX}$ accepted by publishers (formats, support, fonts, and the like)
- get $(\text{\La})\text{\TeX}$ accepted by other communities: SGML, scientific societies
- provide user guides and templates
- education is paramount

- keep it simple and small is beautiful.

and so on.

Prophecy. The demand on IT will be that

people can access cost-effectively, and easily, from their homes the information they need in a representation they wish.

I envision that the following technologies will influence each other in realizing the stated prophecy

- T_EX's role? Embedded in a Hypertext approach?
- Increased self-publishing
- Electronic Production & Consumption
 - + Photography
 - + CD
 - + TV/Radio, video
 - + PC
 - + Phone, fax, email
 - + Holography
 - + ...
- Involvement of linguists and behaviourists

with the functionalities

- Various inputs (o.a. voice, photography, ...)
- Diverse outputs (language, level, media and representation,...)

Some years ago I day-dreamed about holographic-based true 3-D 'displays,' as a generalization of computer-assisted interactive TV. Science-fiction? Wait and see, or better hang on and make it happen!

12 Examples

With a publication we have two main issues: macroscopic and microscopic. With the first I mean the aspects which govern the total outer level of a publication, let us say to look upon it as a tree consisting of

- front matter (front pages (title etc.), publication characteristics, foreword, table of contents and the like)
- copy proper (the chapters and their substructures), and

- back matter (appendixes with references, index, and other special items).

These macroscopic aspects are accounted for in so-called formats or style files.

The microscopic aspects deal with formatting in the small within paragraphs, the complex mark-up of math, tables and graphics.

Another basic way to look at the matter is that it has all to do with

positioning of typographical elements on pages.

The following examples, biased by my own (scientific) needs, are in the main about

- formats, generic and special

and deal in the small with

- special texts like programs
- (displayed) math (formulae, matrices, ...)
- tables
- graphics
- bibliographies, and
- indexes.

So nothing in here about the use of \TeX for non-Latin languages and the design and generation of the needed fonts, simply because I don't speak them. I also refrained from including examples about the hobby use—games—without a serious reason. See NTG's PR set for the latter. See the works of Haralambous with respect to non-Latin languages, and the work of Horak for (math) METAFONT examples.

12.1 Examples: formats.

In this section some detailed formatting examples are provided.

I will consider \LaTeX as formatter for a rudimentary house-style, followed by a generic approach customized to `manmac` and \LaTeX 's report style.

House-style. \LaTeX is heavily used for this *as-is*

```
\documentstyle[options]{house}
%preamble
\begin{document}
%front matter
\title{...}
...
```

```

\begin{abstract}
...
\end{abstract}
\tableofcontents
\listoffigures
\listoftables
%copy proper
%\section, \subsection structuring with
%\paragraphs with (displayed) math, tables
%and graphics.
%back matter
\begin{thebibliography}{xxx}
\bibitem{dek84} Knuth, D.E (1984):...
...
\end{thebibliography}
%Index material (\makeindex tool)
\end{document}

```

Options are, for example, the number of columns,¹⁹ the size of the used fonts, the paper size, and the like.

As style files there are next to report, the styles book, article, letter, and so on.²⁰

Generic mark-up. Many users start nowadays via L^AT_EX. Sooner or later the demand for a generic approach pops up. Then the user wishes to abstract from the concrete formatter and use some higher-level mark-up for the global structuring commands, customizable to a concrete formatter of choice.²¹

The idea is that the *user* mark-up at the outer level is as independent as possible from the concrete formatter.

A generic approach is needed because of the variety of environments we live in and because of their rapid change.

For the generic approach to become realistic, and to handle it gracefully, I assume that

- the opening part is available for the various formats as templates
- the copy proper uses as structuring commands `\head` and the like
- for the detailed formatting plain T_EX is used, so that this can be used in (L^A)T_EX (math, tables, and graphics)

¹⁹It is not true in general that switching from 1-column into 2-column format can be done without altering the mark-up of displayed math, tables or figures. At least one must change locally back into 1-column format, or one has to scale the document element into smaller size as was done in this paper.

²⁰L^AT_EX's SLI_TE_X is a bit different. One can't simply switch from report into slides.

²¹This sounds like SGML, but without its generality and its overhead. I like to call this 'SGML on your mind and T_EX in your hands.'

- for the end matter a generic approach for the bibliography—see my BLUe’s Bibliography paper—is used
- for index preparation a non-specific tool is used.

With the above a generic approach for a house-style is

```
%Front matter
\opening%To be replaced by template
%Copy proper
% Structured via \head{...} and the like
% with detailed plain mark-up: math, tables,
% line diagrams,...
%Back matter
  \bibliography
  \index
\closing
```

Customization to manmac.

manmac is flexible, and alas too much overlooked, because it lacks a user guide. Customization of the generic approach to manmac goes along the following lines to give you an impression. (Not tested!)

```
\input manmac
\input manmac.cus%manmac customization
\input man.tem %manmac template
\input toc %table of contents
\input cover %see my manmac blues
%Copy proper
%Back matter
\closing
```

with in manmac.cus

```
%Customization of manmac
%Redefine \beginchapter also non-outer
\def\beginchapter#1 #2#3.#4\par{%
  \def\hl{\gdef\hl{\issue\hfil\it\rhead}}
  \headline{\hl}
  \def\{ \}\xdef\rhead{#4}
  {\let\cr\halign{\line{\titlefont
    \hfil#\hfil}\#\1 #2#3 #4\unskip\}}
  \bigskip\tenpoint\noindent\ignorespaces}
\def\endchapter{\vfill\eject}
%
\newcnt\chpcnt \newcnt\seccnt
\def\head#1{\endchapter\beginchapter
  \advance\chpcnt1 \seccnt0
  {} \}\the\chpcnt. #1\endgraf}
```

```

\def\subhead#1{\beginsection\advance\secCNT1
  \the\secCNT. #1\endgraf}
\def\bibliography{\beginchapter Bibliography
  {}{}.\}\endgraf}
\def\closing{\bye}

```

and with in `manmac.tem`

```

\def\opening{
\def\issue{%
MAPS Special 93.x           %issue
}\def\title{%
MAPS Special Template      %title
}\def\abstract{%
A template for MAPS Special is provided.
}\def\keywords{%
manmac, MAPS, NTG         %keywords
}
}

```

In my Manmac BLUES paper I have worked out a prototype, directed to customization of `manmac`.

Actually there it was the other way round: I started from Manmac formatting and abstracted into independent structures.

In Manmac BLUES I also worked out `cover`. Too much detail here.

Customization to L^AT_EX.

The ‘title part’-template is inserted instead of `\opening`, edited to suit the publication at hand. In `latex.cus` the macros are supplied to customize the generic mark-up to L^AT_EX.

```

%Begin LaTeX report \opening template
\documentstyle{report}
\input{latex.cus}
\begin{document}
\begin{title}...\end{title}
...
%end LaTeX \opening template
%Copy proper
...
%Back matter
\bibliography
\closing

```

with in `latex.cus`

```

\def\head#1{\chapter{#1}}
\def\subhead#1{\section{#1}}

```

```

\def\bibliography{\appendix
  \section*{Bibliography}
  \input{lit.dat}
  %\input{lit.tex}
  \frenchspacing
  \def\ls#1{\nul\#1}%simple
  \input{lit.sel}
}
\def\closing{\end{document}}

```

The above ideas came to mind when working on this paper. They deserve development, because it has all to do with the

user↔environment interaction,

which has always been important.

Special texts are computer programs. First we like that these reflect the structure and different quantities (constants, variables, reserved words, comments etc.) of the program. Second we like that the programs remain correct while formatting them (meaning: humans hands-off!). These kind of texts come at two levels

- the small examples (less than a dozen of lines or so) which are part of courseware, and
- the documentation (and listings) of real-life programs.

Current practice is that for the first it does not really matter what you use. For a survey see the compilation of Van Oostrum. For the second Knuth developed **WEB**, which stimulates a programmer to design and *document* his program from the beginning, by rewarding him with pretty-**T**_E**X** printing of it all via **TANGLE**. Actually the hierarchical way of working has been replaced by a relational approach, with the documentation related to the various items of a program. For a survey see Knuth's literal programming article of 1984.

12.2 Examples: math.

The **T**_E**X**book has devoted at least 4 chapters to math mark-up: typing math formula, more about math, fine points of math typing, and displayed equations.

See also my **Math into BLUes** paper for a survey and how to cope with situations which go wrong—not so much that **T**_E**X** complains, but the results are different from what we expected—by innocent mark-up.

Displayed math via (plain) TeX. A display is marked up by \$\$ at the beginning and the end. Within a display the following is generally used

- just math mark-up
- `\displaylines`, for multi-liners
- `\(1)eqalign`, for aligned formulas²²
- `\(1)eqalignno`, similar to the above, but numbering per line.

For numbering there is the primitive `\eqno`.

From a user point of view the following are representative structures

- Labeled 1-line

$$\sin 2x = 2 \sin x \cos x \quad (\text{TB186})$$

- Three lines, second flushed right (relevant for 2-column printing)

$$F(z) = a_0 + \frac{a_1}{z} + \frac{a_2}{z^2} + \cdots + \frac{a_{n-1}}{z^{n-1}} + R_n(z),$$

$n = 1, 2, \dots,$

$$F(z) \sim \sum_{n=0}^{\infty} a_n z^{-n}, \quad z \rightarrow \infty \quad (\text{TB ex19.16})$$

- Two lines aligned, with middle labeling

$$\begin{aligned} \cos 2x &= 2 \cos^2 x - 1 \\ &= \cos^2 x - \sin^2 x \end{aligned} \quad (\text{TB193})$$

- Two lines aligned, with labeling per line

$$\begin{aligned} \cosh 2x &= 2 \cosh^2 x - 1 \\ &= \cosh^2 x + \sinh^2 x \end{aligned} \quad (\text{TB192})$$

obtained via

```
\begin{itemize}
\item Labeled 1-line
$$\sin 2x=2\sin x\, \cos x
\eqno(\hbox{TB186})$$
\item Three lines, second flushed right
(relevant for 2-column printing)
$$\displaylines{F(z)=
a_0+{a_1\over z}+{a_2\over z^2}+\cdots
```

²²(1) denotes that the numbering appears at the left instead of the default right.

```

+{a_{n-1}\over z^{n-1}}+R_n(z),\cr
\hfill n=1,2,\dots\,,\cr
\hfill F(z)\sim\sum_{n=0}^{\infty} a_nz^{-n},
\quad z\to\infty\quad\quad\quad\hfill
\llap{(TB ex19.16)}\cr}$$
\item Two lines aligned,
with middle labeling
$$\eqalign{\cos 2x&=2\cos^2x-1\cr
&=\cos^2x-\sin^2x\cr}
\eqno(\hbox{TB193})$$
\item Two lignes aligned,
with labeling per line
$$\eqalignno{\cosh 2x&=2\cosh^2x-1&(\hbox{TB192})\cr
&=\cosh^2x+\sinh^2x\cr}$$
\end{itemize}

```

Matrices via (plain) T_EX. The examples show paradoxically that for practical use we not only need `\matrix`, but

- `\atop`, to stack elements on top of each other
- `\bordermatrix`, for bordered matrices, and this embedded within `\displaylines`
- `\halign`, to handle partitioning, and
- some macros tailored to our situations, like the icon set.

Examples

- Hypergeometric function

$$M_n(z) = {}_{n+1}F_n \left(\begin{matrix} k + a_0, k + a_1, \dots, k + a_n \\ k + c_1, \dots, k + c_n \end{matrix}; z \right)$$

via

```

$$M_n(z)={}_{n+1}F_n\biggl(\{k+a_0,
\atop\phantom{kc_1}\}
\{k+a_1,\dots,k+a_n
\atop k+c_1,\dots,k+c_n\};z\biggr)$$

```

- Some matrix icons, Wilkinson (1965)

$$\begin{array}{c}
\begin{array}{ccc} \square & \triangle & = & \triangle & \square \end{array} & AL = LH \\
\begin{array}{ccc} \square & = & \square & \triangle \end{array} & A = QR
\end{array}$$

via

```

$$\begin{matrix} \text{A} & \text{N} \\ \begin{pmatrix} \times & \times & \times \\ \times & \times & \times \\ \times & \times & \times \end{pmatrix} & \begin{pmatrix} 1 & & \\ 0 & 1 & \\ 0 & \times & 1 \end{pmatrix} \end{matrix}$$

```

See for the matrix icon macros my paper on the issue.

- Matrix reductions, Wilkinson(1965, p357)

$$= \begin{matrix} \text{N} & \text{H} \\ \begin{pmatrix} 1 & & \\ 0 & 1 & \\ 0 & \times & 1 \end{pmatrix} & \begin{pmatrix} \times & \times & \times \\ \times & \times & \times \\ 0 & \times & \times \end{pmatrix} \end{matrix}$$

via

```

$$\begin{matrix} \text{A} & \text{N} & \text{H} \\ \begin{pmatrix} \times & \times & \times \\ \times & \times & \times \\ \times & \times & \times \end{pmatrix} & \begin{pmatrix} 1 & & \\ 0 & 1 & \\ 0 & \times & 1 \end{pmatrix} & \begin{pmatrix} \times & \times & \times \\ \times & \times & \times \\ 0 & \times & \times \end{pmatrix} \end{matrix}$$

```

- Partitioning, Wilkinson(1965, p291)

$$P_r = \left(\begin{array}{c|c} I_{n-r} & 0 \\ \hline 0 & I - 2v_r v_r^T \end{array} \right)$$

via

```

$$\left(
\begin{array}{c}
\text{\vcenter} \\
\text{\offinterlineskip\tabskip0pt} \\
\text{\halign} \\
\text{\vrule height3ex depth1ex width 0pt} \\
\text{\hfil\enspace#\enspace#\hfil} \\
\text{\vrule width.1pt\relax} \\
\text{\&\hfil\enspace#\enspace#\hfil\cr} \\
\text{I}_{\{n-r\}\&0\cr} \\
\text{\noalign{\hrule height.1pt\relax}} \\
\text{0 \&I-2v_rv_r^T\cr} \\
\text{\right)}
\end{array}
\right)$$

```

Next some examples without the mark-up, just the results, because they are real teasers.

- Braces and Matrices, Wilkinson(1965, p199)

$$\begin{array}{c}
p \\
\left\{ \begin{array}{c}
\overbrace{\begin{matrix} \times & \times & \times & \times & \times & \times & \times \\
0 & \times & \times & \times & \times & \times & \times \\
0 & 0 & \times & \times & \times & \times & \times \\
0 & 0 & 0 & \times & \times & \times & \times \\
0 & 0 & 0 & 0 & \times & \times & \times \\
0 & 0 & 0 & 0 & \times & \times & \times \\
0 & 0 & 0 & 0 & \times & \times & \times \end{matrix}}^p & \overbrace{\begin{matrix} \times & \times & \times \\
\times & \times & \times \\
\times & \times & \times \\
\times & \times & \times \\
\times & \times & \times \\
\times & \times & \times \\
\times & \times & \times \end{matrix}}^{n-p}
\end{array} \right.
\end{array}$$

- Matrices, braces, (dotted) partitioning and icons; space efficient variant

$$\begin{array}{c}
p \\
\left\{ \begin{array}{c}
\overbrace{\begin{matrix} \times & \times & \times & \times & \times & \times & \times \\
0 & \times & \times & \times & \times & \times & \times \\
0 & 0 & \times & \times & \times & \times & \times \\
0 & 0 & 0 & \times & \times & \times & \times \\
\dots & \dots & \dots & \dots & \dots & \dots & \dots \\
0 & 0 & 0 & 0 & \times & \times & \times \\
0 & 0 & 0 & 0 & \times & \times & \times \\
0 & 0 & 0 & 0 & \times & \times & \times \end{matrix}}^p & \overbrace{\begin{matrix} \times & \times & \times \\
\times & \times & \times \\
\times & \times & \times \\
\times & \times & \times \\
\times & \times & \times \\
\times & \times & \times \\
\times & \times & \times \end{matrix}}^{n-p}
\end{array} \right.
\end{array}$$

- Other interesting two-dimensional structures are commutative diagrams. Consult for those Spivak's \LaTeX .²³

Interestingly enough, simple commutative diagrams are done by `\matrix`, while I would expect some graphic commands.

²³Within the graphics section I have supplied a simple example, however.

12.3 Examples: tables.

For (full) rectangular tables `\halign` or `\valign` is generally used, when they fit on the page. Because of determining automatically the page breaks it might happen that the page builder would like to split a table. Generally this is bad typography, because we like to maintain the summary character of a table all on one page.²⁴ A table smaller than the page should fit and in order to let that happen we generally allow tables to float, that is they may be shifted around a bit by the page builder. For a survey on the issue see my Table Diversions paper, which also contains a macro for handling bordered tables—the `btable` macro (some 80 lines), and used in this work (see later).

Another important class of tables are the so-called trees. One can argue whether they are tables or belong to graphics. Brüggeman-Klein has provided a package called `TreeTeX`. The user-interface looks good, although I have not had any personal experience with it myself yet.

Simple tables via (plain) `TeX`. When I read Furuta a decade ago, I was impressed by the ease of mark-up for tables via the `tbl` preprocessor of `troff`.²⁵ Below I'll show that a similar functionality—and some more, I also abstracted from the kinds of rules, and the positioning of the elements—is provided with respect to tables by my `btable` macro for the class of bordered tables, where the (possibly complicated) headers are treated separately and independently from the (proper) table data, and the rowstub list.

- just framed data

11	12
21	22

- add header and rowstubs

	Header
1 st row	11 12
2 nd row	21 22

²⁴When the latter is not important, for example for tables of values which goes on for pages, we can modify the row separator into a separator which allows line breaks. For tables which don't fit on a page there are special macros, like `supertabular.sty`.

²⁵Because of that I was in favour of `troff` and its preprocessors. Happily a math professor stressed the importance of `TeX`, and because UNIX was not widely available at the University, I entered `TeX`-land.

- add caption and footer, vary via dotted lines

Caption

	⋮	Header
⋮		
1 st row	⋮	11 : 12
⋮		
2 nd row	⋮	21 : 22

Footer

- vary with ruled and framed

Caption

	Header	
1 st row	11	12
2 nd row	21	22

Footer

via

```

\def\data{11\cs12\rs21\cs22}
\begin{itemize}
\item just framed data
  $$\vcenter{\framed\btable\data}$$
\item add header and rowstubs
  \def\header{\multispan2\hfill
    Header\hfill}
  \def\rowstblst{{$1^{st}$ row}%
    {{$2^{nd}$ row}}
  $$\vcenter{\btable\data}$$
\item add caption and footer,
  vary via dotted lines
  \def\caption{Caption}\def/footer{Footer}
  $$\vcenter{\dotruled\btable\data}$$
\item vary with ruled and framed
  $$\vcenter{\ruled\framed\btable\data}$$
\end{itemize}

```

Real-life. AT&T's example from the tbl (troff) documentation, also supplied in *TeXbook* p.247

AT&T Common Stock

Year	Price	Dividend
1971	41-54	\$2.60
2	41-54	2.70
3	46-55	2.87
4	40-53	3.24
5	45-52	3.40
6	51-59	.95*

* (first quarter only)

The above is obtained via `\btable` as follows

```

\def\caption{AT\&T Common Stock}
\def\header{Year\cs Price\cs Dividend}
\catcode'\?= \active \def?\{\kern1.1ex}
\def\data{1971\cs41--54\cs\llap{\$}2.60\rs
          2\cs41--54\cs          2.70\rs
          3\cs46--55\cs          2.87\rs
          4\cs40--53\cs          3.24\rs
          5\cs45--52\cs          3.40\rs
          6\cs51--59\cs          ?.95\rlap*}
\def\footer{* (first quarter only)}
\$\vcenter{\vbox{\small
  \framed\ruled\btable\data}}\$

```

12.4 Examples: graphics.

The portable way is via `manmac.sty`, L^AT_EX's picture environment, or PiCT_EX. For a survey see Clark's Portable Graphics in *TeX* paper. *TeX*tures on the Macintosh by Blue Sky Research is famous for its (non-portable) *pictures* with *TeX*. For inclusion of photographs and in general halftones, see the work of Sowa.²⁶ For drawing on the screen and get (La)*TeX* code out see GNUplot or *TeXCAD*, for example.

Many disciplines make use of special graphic diagrams. In this paper for example I won't provide examples of trees, (math) graphs in general, (advanced) commutative diagrams, nor Feynmann diagrams, to name but a few classes known to me.

²⁶On the Mac one can easily incorporate photos after they having been put onto CD in digitized form. Kodak provides the latter service.

- simple line diagrams via `manmac.sty`

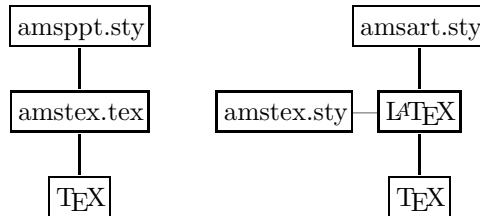

via

```

 $\hbox{\vbox{%
\element{\fbox{amsppt.sty}}
\vconnector
\element{\fbox{amstex.tex}}
\vconnector
\element{\fbox{\TeX}}
}\quad\quad\quad\vbox{%
\element{\fbox{amsart.sty}}
\vconnector
\element{\llap{\fbox{amstex.sty}---}
\fbox{\LaTeX}}
\vconnector
\element{\fbox{\TeX}}
}\}$ 

```

with the auxiliaries

```

\def\strut{\vrule height2.5ex depth1ex
widthOpt}
\def\fbox#1{\setbox0\hbox{\strut
$;#1$,}\leavevmode\rlap{\copy0}%
\makelightbox}
\def\element#1{\hbox to15ex{\hss#1\hss}}
\def\vconnector{\element{\strut\vrule}} .

```

- flow chart borrowed from Furuta, via $L^A T E X$

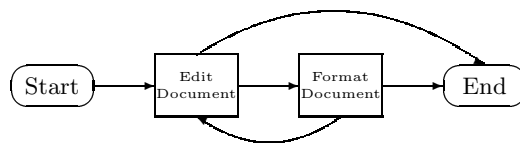

via

```

\setlength{\unitlength}{4ex}

```

```

\begin{picture}(14,4)(0,-1)
\put(1, 1){\oval(2, 1)}
\put(1, 1){\makebox(0, 0){Start}}
\put(2, 1){\vector(1, 0){1.5}}
\put(3.5, .25){\framebox(2,1.5){\shortstack
{\tiny Edit\\ \tiny Document}}}
\put(5.5, 1){\vector(1, 0){1.5}}
\put(7, .25){\framebox(2,1.5){\shortstack
{\tiny Format\\ \tiny Document}}}
\put(9, 1){\vector(1, 0){1.5}}
\put(11.5, 1){\oval(2, 1)}
\put(11.5, 1){\makebox(0, 0){End}}
\bezier{75}(4.5, .25)(6.25, -1)(8, .25)
\put(4.5, .25){\vector(-2, 1){0}}
\bezier{150}(4.5, 1.75)(8, 4)(11.5, 1.5)
\put(11.5, 1.5){\vector(2, -1){0}}
\end{picture}

```

Although the specification is not as easy as via the pic preprocessor, it is not difficult when we start from a template, like the one above. Cumber-
some is the treatment of the arrow heads, but these can be hidden.

- a pie-chart via L^AT_EX

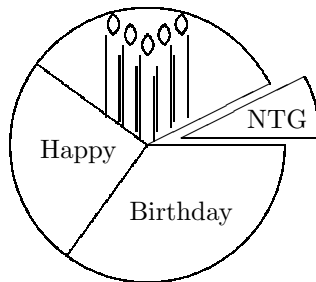

via

```

\setlength{\unitlength}{6ex}
\begin{picture}(6, 5)(-3, -2)
%1st quadrant
%\bezier{100}(2, 0)(2, .54)(1.79, .89)
% 0 - '30' 2:1-line
\bezier{60}(1.79, .89)(1.46, 1.46)(1, 1.73)
% '30' - 60
\bezier{60}(1, 1.73)(.54, 2)(0, 2)
% 60 - 90
%2nd quadrant

```

```

\bezier{60}(0, 2)(-.54, 2)(-1, 1.73)
% 90 - 120
\bezier{60}(-1,1.73)(-1.46,1.46)(-1.73,1)
%120 - 150
\bezier{60}(-1.73, 1)(-2, .54)(-2, 0)
%150 - 180
%3rd quadrant
\bezier{60}(-2, 0)(-2, -.54)(-1.73, -1)
%180 - 210
\bezier{60}(-1.73,-1)(-1.46,-1.46)(-1,-1.73)
%210 -240
\bezier{60}(-1, -1.73)(-.54, -2)(0, -2)
%240 - 270
%4th quadrant
\bezier{60}(0, -2)(.54, -2)(1, -1.73)
%270 - 300
\bezier{60}(1,-1.73)(1.46,-1.46)(1.73,-1)
%300 - 330
\bezier{60}(1.73, -1)(2, -.54)(2, 0)
%330 - 360
%division lines
\put(0, 0){\line(1, 0){2}}
\put(0, 0){\line(2, 1){1.79}}
%1.79 = 2 cos arctg .5
%\put(0, 0){\line(-2, 1){1.79}}
\bezier{75}(0, 0)(-.81, .59)(-1.61, 1.18)
%-.81 = cos 144; .59 = sin 144
%\put(0, 0){\line(-1, -2){.89}}
%.89 = 2 sin arctg .5
\bezier{75}(0, 0)(-.59, -.81)(-1.18, -1.62)
%-.59 = cos -126; -.81 = sin -126
%piece
\bezier{60}(2.5, 0.1)(2.5, .64)(2.29, .99)
% shift .5, .1
\put(0.5, 0.1){\line(1, 0){2}}
\put(0.5, 0.1){\line(2, 1){1.79}}
%Candles:
\bezier{20}(0,1.31)(-.15,1.45)(0,1.61)
\bezier{20}(0,1.31)(.175,1.45)(0,1.61)
\put(-.1, .1){\line(0,1){1.2}}
\put(.1, .05){\line(0,1){.95}}
\put(.1,1){\line(-2,3){.2}}
%left
\bezier{20}(-.25,1.46)(-.40,1.6)(-.25,1.76)
\bezier{20}(-.25,1.46)(-.075,1.6)(-.25,1.76)
\put(-.35, .25){\line(0,1){1.2}}
\put(-.15, .2){\line(0,1){.95}}

```

```

\put(-.15,1.15){\line(-2,3){.2}}
%right
\bezier{20}(.25,1.46)(.40,1.6)(.25,1.76)
\bezier{20}(.25,1.46)(.075,1.6)(.25,1.76)
\put(.35,.25){\line(0,1){1.2}}
\put(.15,.2){\line(0,1){.95}}
\put(.15,1.15){\line(2,3){.2}}
%leftleft
\bezier{20}(-.5,1.61)(-.65,1.75)(-.5,1.91)
\bezier{20}(-.5,1.61)(-.325,1.75)(-.5,1.91)
\put(-.6,.4){\line(0,1){1.2}}
\put(-.4,.35){\line(0,1){.95}}
\put(-.4,1.3){\line(-2,3){.2}}
%rightright
\bezier{20}(.5,1.61)(.65,1.75)(.5,1.91)
\bezier{20}(.5,1.61)(.325,1.75)(.5,1.91)
\put(.6,.4){\line(0,1){1.2}}
\put(.4,.35){\line(0,1){.95}}
\put(.4,1.3){\line(2,3){.2}}
%texts
\put(-1,-.1){\makebox(0,0){\strut Happy}}
\put(.5,-1){\makebox(0,0){\strut Birthday}}
\put(1.9,.35){\makebox(0,0){\strut NTG}}
\end{picture}

```

The above use of the bezier splines makes the creation of scaling invariant circles easier than the approach by Ramek in the proceedings of T_EXeter '88.

- commutative diagrams (L^AT_EX, ...). As a simple example the calculation flow of the autocorrelation function, a_f , inspired by the T_EXBook ex18.46, p.358. \mathcal{F} denotes the Fourier transform and \mathcal{F}^{-1} the inverse Fourier transform

$$\begin{array}{ccc}
 f & \xrightarrow{\otimes} & a_f \\
 \downarrow \mathcal{F} & & \uparrow \mathcal{F}^{-1} \\
 \mathcal{F}(f) & \xrightarrow{\times} & (\mathcal{F}(f))^2
 \end{array}$$

via

```

$$\matrix{f&\lmapright\otimes&a_f\cr
\mapdown{\cal F}&&\mapup{\cal F^{-1}}\cr
\mathcal{F}(f)&\xrightarrow{\times}&(\mathcal{F}(f))^2}

```

```
\hbox to 0pt{\hss$\bigl(\cal F)(f)
\big)^2$\hss}\cr}$$
```

with auxiliaries

```
\def\lllongrightarrow{\relbar\joinrel%
\relbar\joinrel\relbar\joinrel%
\relbar\joinrel\rightarrow}
\def\llongrightarrow{\relbar\joinrel%
\relbar\joinrel\rightarrow}
\def\normalbaselines{%
\baselineskip20pt
\lineskip3pt
\lineskiplimit3pt}
\def\mapright#1{\smash{\mathop{
\llongrightarrow}\limits^{#1}}}
\def\lmapright#1{\smash{\mathop{
\lllongrightarrow}\limits^{#1}}}
\def\mapdown#1{\Big\downarrow
\rlap{\vcenter{\hbox{#1}}}}
\def\mapup#1{\Big\uparrow
\rlap{\vcenter{\hbox{#1}}}}
```

- METAFONT coupled to T_EX. Leading in this area is the work of Hoenig, for example see his ‘When T_EX and METAFONT work together.’ He has worked out the printing along curved lines, and the typesetting of paragraphs which flow around arbitrary shapes! Very powerful, but not simple to use for the moment. It looks like going back to the roots, because Knuth’s first version of the ‘T_EXbook’ contained it all: ‘T_EX and METAFONT, New directions in typesetting.’
- (encapsulated) PostScript. Knuth left some niches for handling these kinds of things via the `\special` command. A very nice survey of the possibilities which can be obtained when incorporating PostScript is given in Goossens’ ‘PostScript en L^AT_EX,’ which is also a chapter in the L^AT_EX-companion. A survey of the various user approaches has been compiled by Anita Hoover.
- Screen drawings. An example is GNUplot. Cameron in T_EXline characterized these kind of systems as

‘... There are a couple of programs available which take all the calculation out: you draw your picture using the mouse, and it is automagically compiled into L^AT_EX source. But for complicated figures, mathematical insight or computational power may be required.’

An example of figures that require math insight are Hoenig’s ‘Fractal images with \TeX .’ We can add to that the reuse aspect, which is hindered by the drawing approach, and the unreadable nature of machine-generated code. But certainly these tools have their niche in the spectrum of tools for EP.

13 Front matter

Much attention is paid to front matter: cover, publication characteristics (source, ISBN or other classification), title etc., abstract, keywords, table of contents and the like if not considered as an appendix, foreword. Basically the style or format can handle these easily. Because of the eye-catching need of a cover a designer is generally involved and the cover, especially the graphics, typeset by different means. The page with publication characteristics can be left to the copy editor. For the others just obey the mark-up characteristics, as demanded by the style file.

14 Back matter

As back matter we have the various appendices. Two kinds are noteworthy: the list of references and the index. Both are complicated because of the *cross-referencing on the fly*.

Bibliography creation. With a publication we have the problem of handling a list of references, to extract them from our literature database, and to format them appropriately. We also like to cross-reference them to the list of references, such that it is adaptable to different journal traditions, with respect to formatting of citations. There are tools available to do that, for example \LaTeX ’s \BIBTeX with its `thebibliography` environment, and \AMS-TeX ’s `\ref` and `\endref` structures. I designed my own ‘little language within \TeX ’ to handle that all in a one-pass job within $(\text{\La})\text{\TeX}$. To get the flavour, the bibliography at the end of this paper has been prepared via

```
\section*{References}
\input{lit.dat}%database file
\def\tubissue#1(#2){\s1 TUGboat\}
\def\ls#1{\ea\bibentry#1\endgraf}
\input{lit.sel}%file with names
```

See my BLUE’s Bibliography paper for more details, and my solution of the cross-referencing in a one-pass job.

Index preparation. This is complicated because of the dynamic allocation of page numbers and inclusion of these in the index. It is also an art to provide the right entries. Generally (external) sorting needs to be done too, next to the formatting. A complicated job.

TeXnically there is the tool Makeindex, to cooperate with (La)TeX.

Knuth provided a mark-up mechanism for extracting the index entries and let the OTR add the page numbers. These items are written on a file for further processing, like sorting, and adding comments and the like. I consider that very powerful, but it is not completely automatic. The user, or publisher, has to account for the finishing touch, for the moment. For a survey of the intricacies which come along when writing automatic index generators, see the report of Chen and Harrison about developing Makeindex.

I have exercised index preparation à la Knuth in my Sorting in BLUe paper. Although the approach of doing it all within TeX looks promising, it still needs some polishing for BLU to become useful.

15 Guidelines for Choosing

Given the above-mentioned variety of tools the following questions can be useful

- What facilities does your publisher provide?
- What is the document like?
- What tools are already in use?
- Whom is it aimed at?
- How many authors are involved?
- Is (partial, e.g. bibliographical) reuse also envisaged?
- Is future use, different from formatting, in sight?

First, contact your publisher and agree upon the tools to be used.

Next best, when you are on your own, consider

No structure (For right-to-left etc.	it does not matter TeX-XET
Scientific papers	(IA)TeX
Reuse	(IA)TeX, SGML?
Various authors	(IA)TeX, SGML?
Future (nonformatting) use	(IA)TeX, SGML?

A user sufficiently fluent in di-roff would like me to substitute x-roff for TeX in the table above. Be my guest, I don't have experience with x-roff.

Acknowledgements

This paper has been processed via L^AT_EX because I needed the functionality of the picture environment. The standard formatting of the peculiar T_EX-related names have been borrowed from `tugboat.cmn`. I used the `ltugproc.sty`—style for TUG proceedings—because of the nice way the front matter is typeset.

I like to thank Christina Thiele for polishing my English and pointing to the right use of fonts for established names.²⁷ Gerard van Nes blew his horn once again. Thank you!

Conclusions

For high-quality computer-assisted typography T_EX etc. is a flexible and excellent craftsman-like tool, with the following characteristics

- T_EX is in the PD, available for all platforms
- flavours of T_EX have been added to facilitate its use, next to macro tool-boxes
- formats and style files have been added to facilitate the publication process
- T_EX can be used with many fonts, and takes its own font generation tool
- drivers, WYSIWYG interfaces are commercially available
- working environments are provided by user groups
- lingua franca for scientific email communication
- publishing houses accept compuscripts marked up by (L^A)T_EX
- users maintain digests, discussion lists and file servers
- some 10k organized users, with many books published via (L^A)T_EX.

Once mastered T_EX is a nice basic tool. However, the way to error-less mark-up is hard and haunting, unless, supported (by a publisher) with generic styles, user's guides, and templates. Using L^AT_EX *as-is* and supported by publishers is much simpler than learning T_EX per se.

The T_EX arcana is complex. (Professional) Education is paramount! The twins T_EX-METAFONT will serve for a lifetime. And above all let us keep it simple!

²⁷Although this has its difficulties simply using \MF for example goes wrong when we vary size.

References

References

- [1] AMS (1991): A look inside the AMS. (A nice brochure of what AMS is all about.)
- [2] AMS (1991): Think about publishing with the AMS. (Another nice brochure about the merits of publishing with AMS: effective marketing, extensive promotion, world-wide distribution, better sales, longer life of book, royalties, support worthwhile noncommercial activities for the benefit of the scientific community at large, for example the \TeX project.)
- [3] AMS (1993): $\mathcal{A}\mathcal{M}\mathcal{S}\text{-}\text{\TeX}$ User's Guide 2.1.
- [4] AMS (1993): $\mathcal{A}\mathcal{M}\mathcal{S}\text{-}\text{\TeX}$ Installation Guide 2.1.
- [5] AMS (1993): $\mathcal{A}\mathcal{M}\mathcal{S}\text{-}\text{\LaTeX}$ User's Guide 1.1.
- [6] AMS (1993): $\mathcal{A}\mathcal{M}\mathcal{S}\text{-}\text{\LaTeX}$ Installation Guide 1.1.
- [7] AMS (1993): AMSfonts. User's Guide 2.1.
- [8] AMS (1993): AMSfonts. Installation Guide 2.1.
- [9] AMS (1993): Guidelines for preparing electronic manuscripts. $\mathcal{A}\mathcal{M}\mathcal{S}\text{-}\text{\TeX}$ (booklet, 52p), and the mirrored one $\mathcal{A}\mathcal{M}\mathcal{S}\text{-}\text{\LaTeX}$ (booklet, 58p). (The first is very well-done. I have not seen a guideline of similar quality of yet! Simply the best available. Much experience is embodied to learn from. The second is verbose, incomplete, and deals at length with issues an author should not be bothered with.)
- [10] APS (1992): The \REVTeX input guide. (From the file server.)
- [11] Beebe, N.H.F (1988): A \TeX driver family. \TeX niques 5, 71–113.
- [12] Beebe, N.H.F (1989): \TeX and graphics: The state of the problem. Cahiers GUTenberg, 2, 13–53.
- [13] Beebe, N.H.F (1991): The TUGlib server. MAPS 91.2, 117–123. (Also \TeX line 11.)
- [14] Beebe, N.H.F (1992): \LaTeX Editing Support. MAPS 92.1, 91–114.
- [15] Beeton, B.N (editor, 1991): TUG Resource Directory. (It contains: TUG membership list, \TeX User Associations, Sources of \TeX software, Output Device Drivers, \TeX archives, Electronic Discussion Lists, \TeX bibliography.)

- [16] Best, R (1993): \TeX zonder omhaal; voor ATARI PC en andere PCs. MAPS 93.1, 57–68. (Also ATARI-ST Journal.)
- [17] Bodenheimer, B (?): Frequently asked questions. comp.text.tex newsgroup. Adapted by Van Oostrum in MAPS 91.1, 85–92.
- [18] Botway, L, C Biemesderfer (198?): \LaTeX command summary. \TeX niques 10.
- [19] Braams, J.L (1991): Babel, a multilingual style-option system for use with \LaTeX 's standard document styles. *TUGboat* **12** (2), 291–301. (Pre-release MAPS 91.1; updated *TUGboat* **14** (1), 60–61.)
- [20] Bruin, R de, C.G van der Laan, J.R Luyten, H.F Vogt (1988): Publiceren met \LaTeX . CWI Syllabus 19. (See also Addendum ‘Publiceren met \LaTeX ’ in MAPS 92.1.)
- [21] Bryan, M (1993): DSSSL. Proceedings TUG '93. *TUGboat* **14** (3), ?–?.
- [22] Bürger, D (1990): \LaTeX for scientists and engineers. MC Graw-Hill.
- [23] Chem- \TeX (?): From the file server.
- [24] Cheswick, B (1990): A permuted index for \TeX and \LaTeX . CSR 145. AT&T. (Also \TeX niques 14. Handy for looking up if a command is already in use.)
- [25] Clark, M (editor, 1990): \TeX applications, uses and methods. Proceedings of Euro \TeX '88. Ellis Horwood. ISBN 0-13-912296-6.
- [26] Clark, M (1992): Portable Graphics in \TeX . Proceedings TUG '92. *TUGboat* **13** (3), 253–260. (Also as chapter 17 in his \TeX Primer.)
- [27] Clark, M (1992): A plain \TeX primer. Oxford University Press. 480p.
- [28] The Chicago manual of style (1982). University of Chicago Press.
- [29] Comm ACM (1988): Special Issue: Hypertext. Comm. ACM, 88, 31, 7. (It contains: An overview of hypertext, by J.B Smith, S.F Weiss; KMS: A distributed hypermedia system for managing knowledge in organizations, by R.M Akscyn, D.L McCracken, E.A Yoder; Reflections on notecards: seven issues for the next generation of hypermedia systems, by F.G Halasz; HAM: A general purpose hypertext abstract machine, by B Campbell, J.M Goodman; Abstraction mechanisms in hypertext, by P.K Carg; Hypertext and the new Oxford dictionary, by D.R Raymond, F.W Tompa; Searching for information in a hypertext medical handbook, by M.E Frisse; Hypertext '87: Keynote address, by A van Dam. There are conferences devoted to the subject at least each year.)
- [30] Dobrowolski, A, E (1992): Typesetting SGML documents using \TeX . Proceedings TUG '92. *TUGboat* **12** (4), 409–414.

- [31] Dol, W, E.H.M Frambach, M van der Vlek (1993): 4 \TeX : a \TeX workbench for MS-DOS PCs. MAPS 93.1, 53–56.
- [32] Doob, M (1990): A gentle introduction to \TeX . \TeX niques 12. (Also from the file server, as is my review.)
- [33] DRILCON (1990): A program for conversion between \TeX and wordprocessors. KUB. The Netherlands. (It uses an intermediate language.)
- [34] Durst, L.K (1989): Bibliographic citations, or variations on the old shell game. *TUGboat* **10** (3), 390–394. (It discusses how to cope with \TeX ing a bibliography. BLUE’s Bib has undoubtedly been influenced by this work, because I read it at least a year before creating BLUE’s Bib. Durst does not use the list separator \TeX nique, and therefore the encoding is a little more complex. Also the writing to a file and the external sorting makes it more cumbersome. In the paper it is not worked out how to use it within one of \TeX ’s flavours. The basic approach is very similar to mine, however.)
- [35] Durst, L.K (1991): Some tools for making indexes: Part I. *TUGboat* **12** (2), 248–258.
- [36] Dyson, M.C (1992): The curriculum as a hypertext. EP-ODD, 5, 2, 63–72.
- [37] Furuta, R, J Scofield, A Shaw (1982): Document Formatting Systems: Survey, Concepts, and Issues. *Computing Surveys*, 14, 3, 417–472.
- [38] Goossens, M (1993): POSTSCRIPT en \LaTeX , de komplementariteit in de praktijk. MAPS 93.1, 101–113.
- [39] Goossens, M, F Mittelbach, A Samarin (1993): The \LaTeX -companion. Addison-Wesley.
- [40] Greenwade, G.D (1993): The Comprehensive \TeX Archive Network—CTAN. TUG ’93. *TUGboat* **14** (3), ?–?.
- [41] Haralambous, Y (1992): \TeX conventions concerning languages. TTN, 1, 4, 3–10.
- [42] Henderson, D (1989): Introduction to METAFont. *TUGboat* **10** (4), 467–480.
- [43] Herwijnen, E van (1990): Practical SGML. Kluwer.
- [44] Hoenig, A.J (1989): Fractal images with \TeX . Proceedings TUG ’89. *TUGboat* **10** (4), 491–497.
- [45] Hoenig, A.J (1991): \TeX for new users. MAPS 91.2, 91–96.
- [46] Hoenig, A.J (1992): When \TeX and METAFont work together. Euro \TeX ’92 proceedings, 1–19. (An updated version released in MAPS 93.1.)

- [47] Hoover, A.Z (1991): Getting Postscript into \TeX and \LaTeX documents. TUG '91. MAPS 91.2.
- [48] Hoover, A.Z (1992): The key to successful support: knowing your \TeX and \LaTeX users. Euro \TeX '92 proceedings, 1–19. (Also MAPS 92.2.)
- [49] Horak, K (priv. comm. 1992): Examples of (scientific) METAFont use. (Some have been incorporated in NTG's PR set.)
- [50] Horn, B.K.P (1993): Scalable outline fonts. TUG '93. *TUGboat* **14** (3), ?–?.
- [51] Hosek, D (1991): \TeX Output Devices. TUG Resource Directory, 133–158.
- [52] Jones, D.M (1992): A catalogue of \TeX macros. (From the file server.)
- [53] Keller, A.M (1985): From text to \TeX —coursenotes for \TeX for beginners. (TOPS 20 is outdated. emacs is still actual.)
- [54] Knuth, D.E (1979): \TeX and METAFont: New directions in typesetting. Part 1 Mathematical Typography. 45p. Part 2 \TeX a system for technical text. 201p. Part 3 METAFont, a system for alphabet design. 105p. AMS. Digital Press. ISBN 0-932376-02-9. (A nice and handy book which explains the basic approaches in not too much detail.)
- [55] Knuth, D.E (1984): Literate Programming. *The Computer Journal*, 27, 2., 97–111.
- [56] Knuth, D.E (1984): Computers and Typesetting. The \TeX book. Addison-Wesley. ISBN 0-201-13447-0 (hard cover) ISBN 0-201-13448-9 (soft cover). (For the correct printing look in the index for `\language` or `\emergystretch`.)
- [57] Knuth, D.E (1984): A course on METAFont programming. *TUGboat* **5** (2), 105–118.
- [58] Knuth, D.E (1986): Computers and Typesetting. The METAFont book. Addison-Wesley. ISBN 0-201-13445-4.
- [59] Knuth, D.E, T Larrabee, P.M Roberts (1989): Mathematical writing. MMA Notes, 14.
- [60] Knuth, D.E (1990): Virtual Fonts: More Fun for Grand Wizards. *TUGboat* **11** (1), 13–23.
- [61] Kołodziejska, H (1991): Go diagrams with \TeX . MAPS 91.2, 63–68. (From the file server.)
- [62] Kopka, H, P.W Daly (1993): A guide to \LaTeX —Document preparation for beginners and advanced users. Addison-Wesley. ISBN 0-201-56889-6.

- [63] Laan, C.G van der, J.R Luyten (1988): Evaluation of K-talk. RC-RUG rapport 15. (Contains test collection for evaluating converters. The conclusion is that ordinary marked up text is no problem, but tables, math and graphics go wrong.)
- [64] Laan, C.G van der (1990): Typesetting Bridge via \TeX . *TUGboat* **11** (2), 265–276. (Pre-release GUTenberg Cahiers 5, and a copy in MAPS 91.2.)
- [65] Laan, C.G van der (1990): SGML(, \TeX and ...). *TUGboat* **12** (1), 90–104. (Pre-release MAPS 90.2 and GUTenberg cahiers 5. It contains also an extensive bibliography about SGML- \TeX relation.)
- [66] Laan, C.G van der (1991): Math into BLUes. Part I: Mourning. TUG '91. *TUGboat* **12** (3), 485–501. Part II: Sing your song. Euro \TeX '91. GUTenberg Cahiers 10&11, 147–170. (Pre-release MAPS 91.1.)
- [67] Laan, C.G van der (1992): Table Diversions, MAPS 92.2, 115–129. (An earlier version at Euro \TeX '92.)
- [68] Laan, C.G van der (1992): Spivak's Œuvre. MAPS 92.1, 139–142.
- [69] Laan, C.G van der (1992): FIFO and LIFO sing the BLUes. *TUGboat* **14** (1), 54–59. (An earlier version at Euro \TeX '92, 225–234, and MAPS 92.2.)
- [70] Laan, C.G van der (1992): Typesetting crosswords via \TeX , revisited. MAPS 92.2, 145–146. (Submitted TUGboat. An earlier version based upon `\halign` in Proceedings Euro \TeX '92, 217–224, and MAPS 92.1, 128–132.)
- [71] Laan, C.G van der (1992): Syntactic Sugar. TUG '93. *TUGboat* **14** (3), 310–318. (Earlier versions in MAPS 92.2, abridged in GUST bulletin 1.)
- [72] Laan, C.G van der (1993): Manmac BLUes—or how to typeset a book via \TeX . MAPS 93.1, 171–191.
- [73] Laan, C.G van der (1993): AMS BLUes—professionals at work. MAPS 93.1, 192–212.
- [74] Laan, C.G van der (1993): Sorting in BLUe. MAPS 93.1, 149–170. (Abridged TUG '93. *TUGboat* **14** (3), 319–328.)
- [75] Laan, C.G van der (1993): Typesetting number sequences. MAPS 93.1, 145–148. (Submitted TUGboat. No longer relevant when BLUe's Bib is used.)
- [76] Laan, C.G van der (1993): Matrix icons via \LaTeX . MAPS 93.2, ?-?.
- [77] Laan, C.G van der (1993): BLUe's Bibliography. MAPS 93.2, ?-?.
- [78] Laan, C.G van der (in progress): TUGboat BLUes—how \TeX ies do it.
- [79] Lamport, L (1985?): Bezier.sty. (For drawing arbitray lines within the picture environment. From the file server.)

- [80] Lamport, L (1985): *L^AT_EX User's Guide & Reference Manual*. Addison-Wesley. ISBN-0-201-15790-X. (With respect to *B_IB_TE_X* the following characteristics from UKTUG meeting of 1990. Advantages: clear layout of database, unique identifier for elements, compatibility with Scribe databases, explicit statement of citation type, extensible style language, uses *L^AT_EX*'s cross-referencing, easy to edit output, can be mixed with non-automatic generated bibliographies, cross-referencing and abbreviations. Disadvantages: multiple passes (*L^AT_EX*, *B_IB_TE_X*, *L^AT_EX*, *L^AT_EX*); have to remember unique references, style language is opaque, database is very wordy and boring to enter.)
- [81] Lamport, L (1987): *Makeindex: An index processor for L^AT_EX*. (From the file server.)
- [82] Lavaud, M (1991): *As_TE_X*. *Euro_TE_X '90*. Cahiers Gutenberg. (Since then in *Euro_TE_X '92*, and *TUG '93*. *TUGboat* **14** (3), ?-?.)
- [83] Mattes, E (1990?): *em_TE_X*. (PD version for MS-DOS PCs, in general use. From the archives.)
- [84] Mittelbach, F (1991): *E-_TE_X*: Guidelines for future *T_EX* extensions. *TUGboat* **11** (3), 337–345. (Redistributed: MAPS 93.1)
- [85] Mittelbach, F, R Schöpf (1989): The new font selection scheme. Reprint: *TUGboat* **11** (2), 297–305. (See also NFSS 2, in Goossens, Mittelbach, Samarin.)
- [86] Mittelbach, F, R Schöpf (1992): The Pursuit of quality. *Electronic Publishing '92*. ISBN 0-521-43277-4. (Redistributed MAPS 92.2.)
- [87] Mittelbach, F, C.A Rowley (1993): The *L^AT_EX3* project. MAPS 93.1, 95–99. (Also in various early nineties proceedings.)
- [88] Mittelbach, F, C.A Rowley, M.J Downes (1993): Volunteer work for *L^AT_EX3* project. *TUGboat* **13** (4), 510–515.
- [89] Oostrum, P van (1991): Program text generation with *T_EX/L^AT_EX*. MAPS 91.1, 99–105. (A survey of the available tools.)
- [90] Quin, L.R.E (1990): Summary of METAFont fonts available. *T_EXMaG*, 4, 6, 1990 (Also MAPS 91.1.)
- [91] Rahtz, S.P.Q (1987): Bibliographic tools. *Literary and linguistic computing*, 2, 4, 231–241.
- [92] Ramek, M (1988): Chemical structure formulae and X/Y diagrams with *T_EX*. *Proceedings Euro_TE_X '88*, 227–258.
- [93] Salomon, D (1992): NTG's Advanced *T_EX* course: Insights and Hindsights. MAPS Special, $\approx 500p$.

- [94] Samuel, A.L (1985): First grade \TeX —A beginners \TeX manual. \TeX niques 11. (Beautiful, obligatory reading! Even for \LaTeX devotees, and for every novice. The layout is nice too. Only some 30p.)
- [95] Schrod, J (1992): The DVI Standard, level 0. The TUG DVI Driver standards committee. *TUGboat* **13** (1), 54–57.
- [96] Sewell, W (1989): Weaving a program—Literate programming in WEB. Van Nostrand. ISBN 0-442-31946.
- [97] Southall, R (1984): First principles of typographic design for document production. *TUGboat* **5** (2), 79–90. (Corrigenda (1985): *TUGboat* **6** (1), p.6.)
- [98] Southall, R (1985): Designing a new typeface via METAFONT. STAN-CS-85-1074.
- [99] Sowa, F (1991): Graphics and halftones with BM2font. TUG '91, *TUGboat* **12** (4), 534–538.
- [100] Spivak, M.D (1986): The Joy of \TeX — \LaTeX - \TeX . AMS. ISBN 0-8218-2999-8. (Updated 2nd printing 1990.)
- [101] Spivak, M.D (1989): \LaTeX - \TeX —The Synthesis. \TeX plorators Corporation.
- [102] Spivak, M.D (1991): \LaTeX - \TeX —The wizards manual. \TeX plorators Corporation.
- [103] Swanson, E (1986): Mathematics into Type. AMS.
- [104] Taylor, P (1992): The future of \TeX . In: Proceedings Euro \TeX '92. 235–254. (Reprinted in *TUGboat* **13** (4), 433–442.)
- [105] Tobin, G (1988): METAFONT for beginners. (From the file server.)
- [106] Treebus, K (1988): Tekstwijzer, een gids voor het grafisch verwerken van tekst. SDU. Den Haag.
- [107] TUG (publications): *TUGboat*, TTN, \TeX niques. (*TUGboat*: Scholarly quaterly of TUG, with the proceedings of the annual meeting as special issue, and the resource directory as supplementary issue. From 1979 onward. \TeX niques: Special themed editions, with no 1 to 14 of 1993) TTN: A portable quaterly newsletter of TUG. From 1990 onward.)
- [108] Tutelaers, P (1991): A font and a style for typesetting chess using \LaTeX or \TeX . MAPS 91.2, 41–45. (Also *TUGboat* **13** (1), 85–90.)
- [109] Urban, M (1986): An introduction to \LaTeX . TRW Software Productivity Project. \TeX niques 9.

- [110] Vens, E.J (1992): Incorporating POSTSCRIPT fonts in \TeX . In: Proceedings Euro \TeX '92, 173–181. (Also in MAPS 92.2.)
- [111] Williams, T, C Kelley (199?): GNUplot: an interactive plotting program. Version 3.
- [112] Winnink, J.J (editor, 1993): NTG's PR set. MAPS '93 Special, \approx 25p. (Contains: Wat is \TeX ?, Hoenig's \TeX for new users, 4 \TeX /em \TeX information, and examples with respect to math, tables, graphics, and the hobbies bridge, chess, and music.)
- [113] Winograd, T, B Paxton (1980): An indexing facility for \TeX . *TUGboat* **1** (x), A1–A12. (The work uses \TeX version 1.x and a Lisp program. It does not contain such a clear user guide as for makeindex. It provides numbers in range notation and allows for subentries, and cross-references like see . . . and see also The program can merge files. The program has been converted into Pascal some years later. The latter version is available on file servers.)
- [114] Youngen, R (1989): Computers and Mathematics. Notices AMS. (Discusses \TeX , \LaTeX and $\mathcal{A}\mathcal{M}\mathcal{S}\text{-}\TeX$, summarizing also the relative advantages. Since the publication of this note $\mathcal{A}\mathcal{M}\mathcal{S}\text{-}\LaTeX$ has been released, and Spivak has provided $\mathcal{A}\mathcal{M}\mathcal{S}\text{-}\TeX$. Of course these are not dealt with.)
- [115] Youngen, R (1991): Typesetting with \TeX at the AMS. 4p. (A nice survey of why-and-what AMS is using \TeX for.)
- [116] Youngen, R (1992): \TeX -based production at AMS. MAPS 92.2, 63–68.
- [117] Zbikowski, R (1993): Hacker's guide to AMSfonts and NFSS in the context of \LaTeX . *TUGboat* **14** (1), 62–69.
- [118] Zlatuska J (1991): Virtual fonts with accented letters. Cahiers GUTenberg 10&11, 57–68.
- [119] Zlatuska, J (editor, 1992): Proceedings Euro \TeX '92. Masarykova universita, Brno. ISBN 80-210-0480-0.